

# INSTALLATION GUIDELINES

AQUAPLANK®



*Signature*®  
signaturefloors

### GENERAL CONDITIONS

A good preparation is essential for a smooth installation. *AquaPlank®* can be installed on concrete, timber, ceramic and many other sub-floors which have been suitably prepared.

The effective application of *AquaPlank®* is dependent on suitable site conditions.

*AquaPlank®* must NOT be installed either externally or into unheated locations. It is possible to install *AquaPlank®* flooring over floors incorporating underfloor heating, but these must be insulated to ensure surface temperature does not exceed 27°C. Before you start, switch off the underfloor heating. The floor should not exceed a temperature of 18°C; before, during and 24 hours after installation of the laminate, gradually increase in increments of 3°C per day until it reaches the maximum operating temperature of 28°C, before being turned back to its normal household temperature.

### SUBSTRATE PREPARATION

Sub-floor preparation is vital for an excellent floor appearance and good installation. The sub-floor must be hard, flat, smooth, clean, dry, and free from defects and fit for purpose and have less than ±5mm over 3000mm deflection.

If required, a suitable levelling compound should be used to ensure that no irregularities impact the finished floor. However, the selection of suitable materials, including smoothing and levelling compounds and any ancillary products, is dependent upon the end use of the completed flooring and must be agreed by the supplier of the preparative materials and the installer.

Any proprietary materials used for floor preparation must be used in accordance with the manufacturers' recommended instructions.

Because our product is waterproof, the sub-floor moisture will not affect the floor itself. But excessive sub-floor moisture may result in smell or mold below the flooring. Concrete substrate moisture should not exceed 95% RH (relative humidity) when tested in accordance with ASTM F 2170.

The finished appearance of an *AquaPlank®* floor will be as good as the quality of the base over which it is installed. Any intense irregularities in the sub-floor may affect performance. Wooden sub-floors must be constructed according to local building codes,

be structurally sound and deflection free. Repair any squeaky floor prior to installation, sand or plane high spots, fill all low spots to ensure the sub-floor levelness does not exceed ±5mm over 3000mm span.

Wooden sub-floors constructed over a crawl space must have adequate ventilation, and minimum ground clearance of 400mm.

### ACCLIMATISATION

*AquaPlank®* performs to its specifications when laid at room temperature between 18°C – 28°C. The product should be acclimatised within the room it is to be laid at least 48 hours prior to installation. A constant temperature, fluctuating no more than 3°C per day and not below the required 18°C room temperature and 18°C floor temperature, should be maintained 24 hours before, during and after installation.

It is preferable that the packs are stored lying flat, stacked squarely and away from vents and direct sunlight. It is recommended that you black out windows where direct sunlight streams in onto the floor to allow for continuity across the whole area to be laid.

### PRE-INSTALLATION

1	Before installation, check all panels in daylight for possible defects. Check that the tongue and groove of the Click laminate profile is free from dirt and undamaged.
2	The surface beneath the floor must be sufficiently prepared in advance to guarantee successful fitting of the floor covering. In particular, it must be clean, dry, smooth, firm, level, free from defects and not contaminated with grease, oil or chemicals.
3	Undercut all door jambs and ensure the compatibility of the underlay being used.
4	Ensure 10mm gap around perimeter of the room and fixtures.
5	Ensure expansion joints are used in areas exceeding 20m in either direction.
6	<i>AquaPlank®</i> is a "floating" floor. The panels should not be glued or fixed to the surface below. Do not fix skirting boards to laminate flooring.

### VAPOR BARRIER AND UNDERLAY

Signature Floors recommends the use of LuxeLay™ underlay on all installations, this a combined vapour

barrier and 2mm closed cell underlay, which will provide a vapor barrier on concrete and wooden substrates, along with acoustic and insulation comfort benefits. The importance of an underlay cannot be overstated. Proper application and installation of underlay and sub-floors is crucial to the proper wear and stability of any flooring.

### EXPANSION

Apart from the first acclimatisation period of 48 hours before unpacking the planks, *AquaPlank®* remains sensitive to expansion and contraction even after installation. This feature can easily be compensated for if you leave an expansion joint of 10mm on all sides, around door frames and thresholds.

### INSTALLATION

1. After thoroughly cleaning the sub-floor, install the LuxeLay™ underlay in the same direction as the flooring planks. The underlay should be butted side-by-side with slight overlap on the backing and ensure to tape seams together with moisture resistant tape.

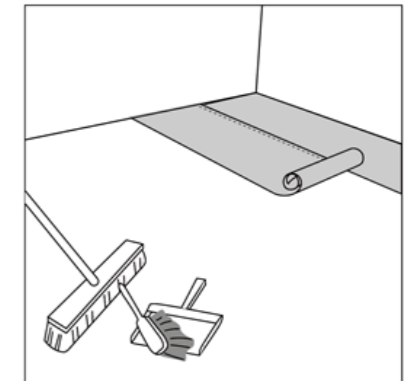

2. Begin laying in the left-hand corner. Place the floorboard 10mm from the left wall. Use spacers between the wall and the floorboard.

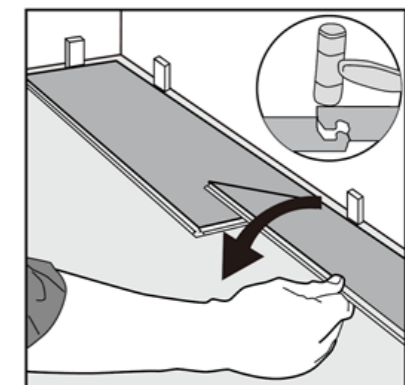

To complete the first row, drop the second plank and gently press down the end with a rubber mallet so it firmly locks. Make sure both planks are perfectly aligned.

**NOTE:** If you notice both planks aren't at the same height or are not well locked together, please follow the disassembling instructions at the end of this document to disassemble and check if any debris stuck inside the lock is obstructing.

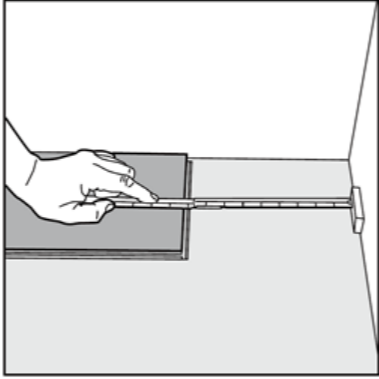
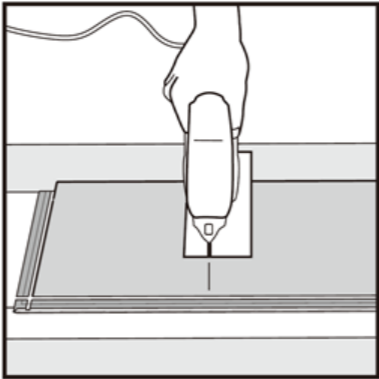
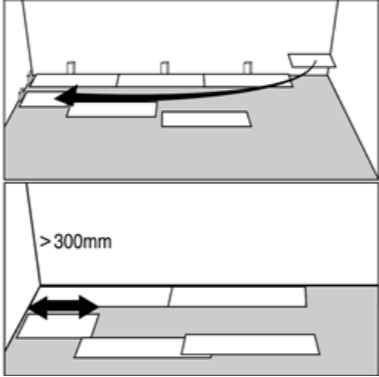

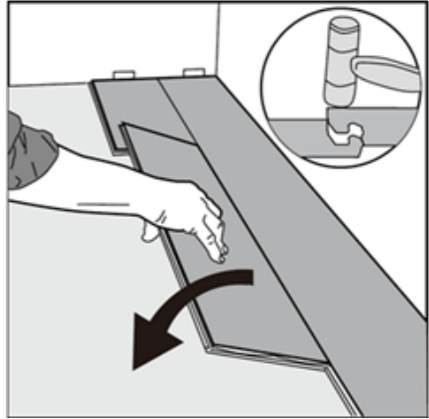
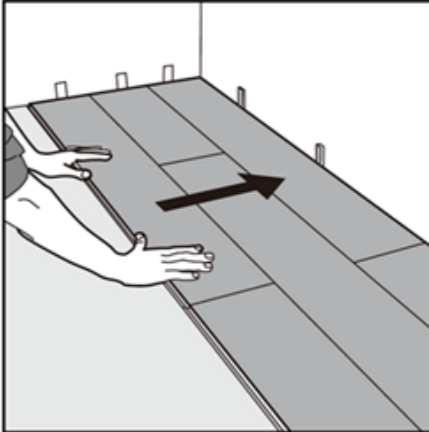
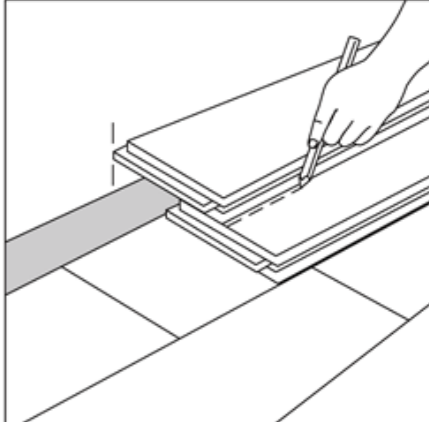
<p>3. At the end of the first row, leave an expansion gap of 10mm to the wall and measure the length of the last plank to fit.</p>	
<p>4. If cutting with a jig saw, the laminate surface should be turned down. If cutting with a hand saw, the laminate surface should be face up.</p> <p><b>NOTE: For Bathroom, Laundry Room or Commercial Installations</b> it is important to seal any cut planks to ensure superior and warranted performance. When a flooring plank is cut to fit (either end cuts or side cuts), a sealant is always required around the perimeter of the installation.</p> <p>Once the flooring installation is completed, a general Silicone based sealant should be applied around the perimeter (in the expansion space at walls) in wet areas only.</p>	
<p>5. Start the second row with the leftover cut part of the last plank of the previous row. This small plank should measure at least 30cm. Otherwise, use another plank that should be cut in two. At any case, the short sides cut are distant from at least 30cm.</p>	

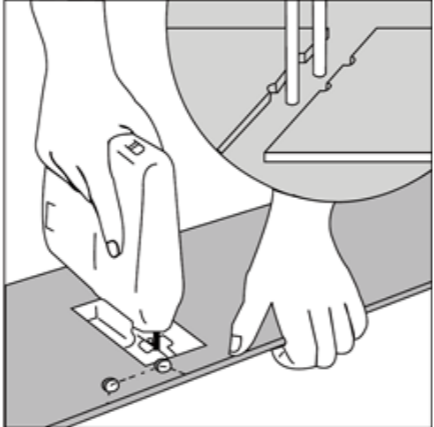
<p>6. Click the long side of the plank into the previous row and place it tight to the short end of the previous plank.</p> <p>Drop the plank and gently press down the end with a rubber mallet so it firmly locks into the previous plank until both are at the same height. Make sure both planks are perfectly aligned and locked into the previous row leaving no gap (refer to "Helpful Hint" on the next page).</p> <p><b>NOTE:</b> If you notice both planks aren't at the same height or are not well locked together, please follow the disassembling instructions at the end of this document to disassemble and check if any debris stuck inside the lock is obstructing.</p>	
<p>7. After 2-3 rows. Adjust the distance to the front wall by leaving an expansion gap of 10mm. Always ensure that the end joints are staggered at least 30cm, both when in the same row as when from one row to the next one.</p>	
<p>8. To lay the last row, position a loose board exactly on top of the last row laid. Place another board on top, with the tongue side touching the wall. Draw a line along the edge of this boards, to mark the first board. Cut along the edge of this board to mark the first board. Cut along this line to obtain of the required width. Insert this cut board against the wall. The last row should be at least 50mm wide. The spacers can then be removed</p>	

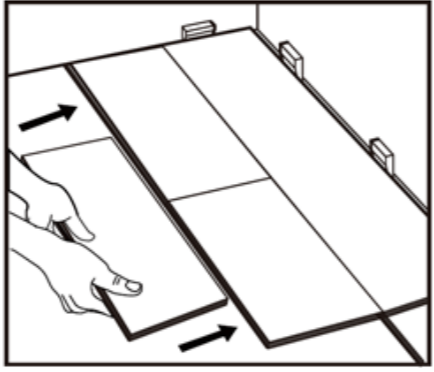
<p>9. To create holes for pipes, measure the diameter of the pipe and drill a hole that is 20mm larger. Saw off a piece as shown in the figure and lay the board in place on the floor, then lay the sawed-off piece in place.</p>	
<p>10. For architraves and skirting, lay a board (with the decorative side down) next to the architrave as shown in the figure. Under-cut the architrave and door jamb, allowing 1mm gap between AquaPlank® and underside of the jamb, and then slide the floorboard under door frame.</p> <p><b>Helpful Hint:</b> When installing each new row, take a full loose plank and use the long side to tap against the prior row to ensure no gapping.</p>	 

**DISASSEMBLING**

Separate the whole row by lifting it up delicately at an angle. To separate the planks, leave them flat on the ground and slide them apart.



For any assistance please contact Signature Floors on 1800 150 554.

**WARRANTY**

Further information is available in our *AquaPlank®* Care Guide & Warranty guideline from your place of purchase and Signature Floors website [www.signaturefloors.com.au](http://www.signaturefloors.com.au)

## **AquaPlank® - Installation Guidelines**

**Document ID: 100064**

**Revision No: 01**

**Date modified: 19/11/2018**

---

Signature Floorcoverings Pty Ltd  
ABN 45 007 172 938  
PO Box 1122 Epping 3076 VIC  
13 Wurundjeri Drive, Epping 3076 VIC Australia  
Tel: 03 9401 0888 Fax: 03 9401 0866  
**[www.signaturefloors.com.au](http://www.signaturefloors.com.au)**

PO Box 527, Silverdale, Auckland 0944  
7B Furnace Place, Silverdale, Auckland 0932  
Tel: 0800 150 555  
**[www.signaturefloors.co.nz](http://www.signaturefloors.co.nz)**

The logo for Signature Floors, featuring the word "Signature" in a large, elegant, cursive script font, with a registered trademark symbol (®) to its upper right. Below "Signature" is the word "signaturefloors" in a smaller, lowercase, sans-serif font.